

5100 feature highlights

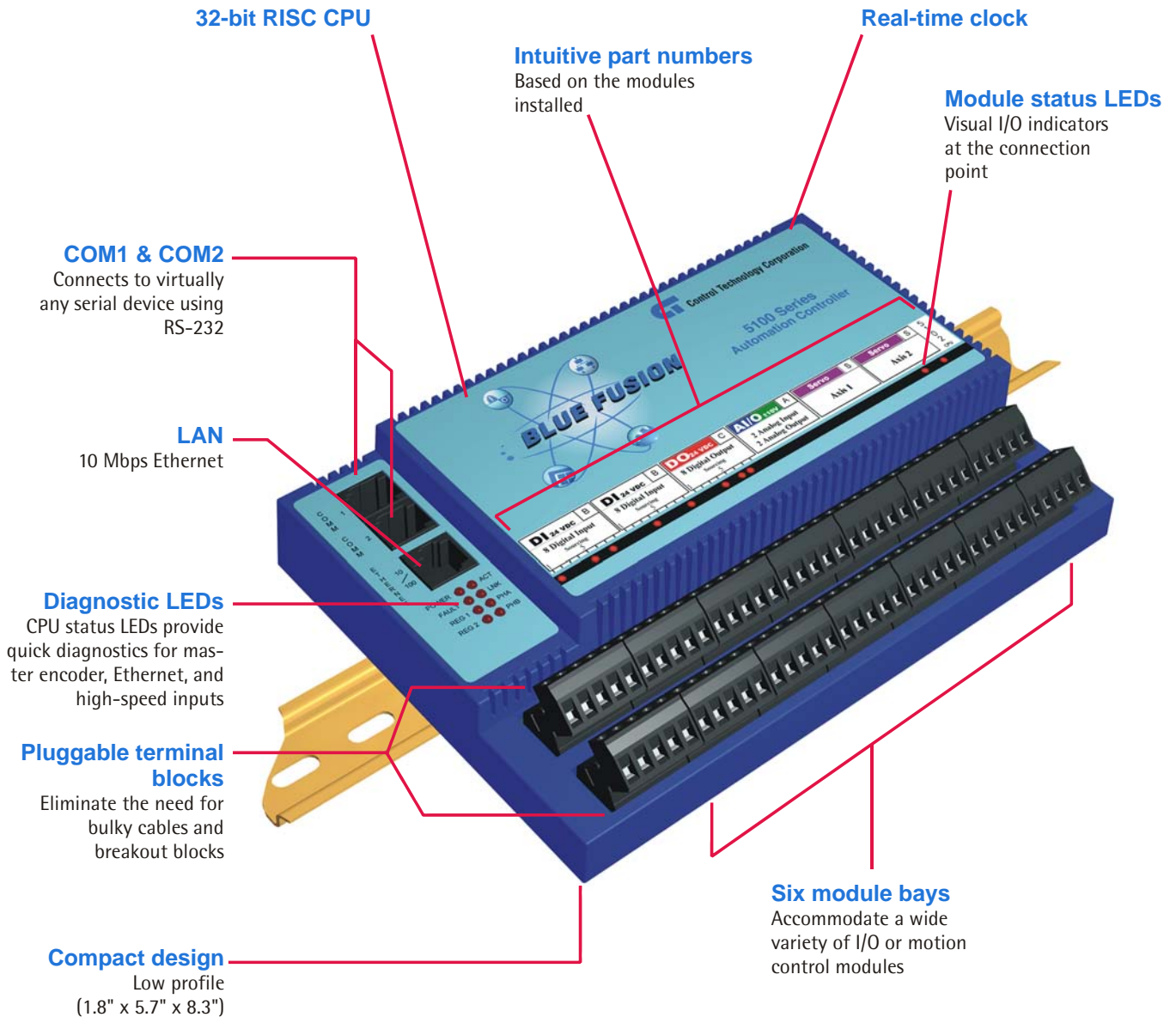

5100 specifications

General specifications

System resources

- 32-bit RISC CPU (28 MHz)
- Industrial real-time deterministic OS
- Real-time clock

User memory

- 128K user memory

Active program resources

- 4,500 non-volatile registers
- 16,000+ element data table
- 84 simultaneous tasks

Environmental

- Operating temperature: 0 – 50°C
- Storage temperature: -40 – 85°C

Performance specifications

Encoder and high speed counters (optional)

- Quadrature and encoder input (6 MHz)

Analog I/O (max 48 channels)*

- Voltage, current and thermocouple
- PID loop control

Digital I/O (max 48 channels)*

- Hardware counters 10 KHz/channel
- Supports 16 PLS outputs, actuation rate < 1msec
- Optional quadrature encoder input with 32-bit counter and 2 additional high-speed (1 microsecond response) registration inputs

Motion control (4 axes per controller)*

- Stepper
 - Velocity range: 0 – 1M steps/sec
 - Accuracy: ± 1 count
- Servo
 - Position loop rate: 500 μ sec/axis
 - Velocity range: 0 – 6M counts/sec

*Maximums are per controller or rack unit and are not necessarily mutually inclusive.

Networking specifications

Ethernet communications

- Supports wired and wireless networking
- UDP, TCP/IP
- Modbus master/slave (ASCII or RTU)
- Raw socket support

Serial communications

- Two RS-232 serial COM ports (38.4 Kbaud)

5100 specifications

Power, COM, and encoder specifications

Parameter	Value
Supply voltage^{1,2}	
5101 / 5102	18-27.0 VDC
5103 / 5104	10-27.0 VDC
Supply current @ 24 VDC	
Quiescent (comm inactive)	150 mADC
Fully loaded (all comm / Ethernet active)	384 mADC
External +5 VDC power ³	5 VDC \pm 10%; 2 ADC
Encoder inputs	
Type - RS-485 compliant	5 V Diff.
Termination resistor	100 Ω
Max. frequency	6 MHz
Registration inputs	
Minimum ON voltage ⁴	0.73 * VS
Maximum OFF voltage ⁴	0.61 * VS
Maximum input voltage ⁴	VS
Maximum input current	1.2 mADC
Input resistance	20k Ω \pm 10%

Parameter	Value
Communications capacities	
Ethernet (IEEE 802.3)	
No. of ports	1
Speed (auto-negotiating, full or half duplex)	10 Mbps
Media type	Base-TX
Connector type	8-pin Telco (RJ-45)
Isolation from CPU	1500 VDC
RS-232	
No. of ports	2
Max. speed	38.4 Kbaud
Default speed	19.2 Kbaud
Connector type	4-pin Telco (RJ-11)
Isolation from CPU	500 VDC
Max. Tx/D / Rx/D voltage	\pm 10 VDC

Notes

1. When analog I/O modules are installed in a controller, it is recommended that the controller be powered via a dedicated linear power supply.
2. Power to each controller should be individually fused with a 30 VDC (minimum) rated 5.0 amp, fast-acting fuse.
3. Derived internal to the controller to be used to power analog I/O modules as well as external encoder circuits.
4. VS refers to the voltage supply of the controller.

5100 specifications

Pinouts, connector and LED specifications

Connector Pinouts

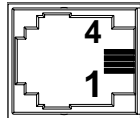

Pin #	Signal
1	TxD
2	Common
3	Common
4	RxD

Ethernet 10 base-T pinouts

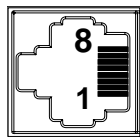

Pin #	Signal
1	TX0+
2	Tx0-
3	RX1+
4	NC ¹
5	NC ¹
6	RX1-
7	NC ¹
8	NC ¹

Power and input terminations

TB1-1	+VS Input
TB1-2 ²	REG1
TB1-3 ²	+PHA
TB1-4 ²	+PHB
TB1-5	+5 VDC Output
TB2-1	VS Return
TB2-2 ²	REG2
TB2-3 ²	-PHA
TB2-4 ²	-PHB
TB2-5	VS Return

LED identification

Power	Off = Power failure On = Normal operation	ACT Ethernet activity	Off = No activity Flashing = Activity
Fault Controller status	Off = Normal operation Solid = Hardware fault Slow flash = software fault Fast flash = DHCP negotiation	LNK Ethernet link	Off = Not connected On = Connected
REG1 ² REG1 status	Off = Open circuit On = Closed circuit	PHA ² PHA status	Off = Open circuit On = Closed circuit
REG2 ² REG2 status	Off = Open circuit On = Closed circuit	PHB ² PHB status	Off = Open circuit On = Closed circuit

Connector Identification

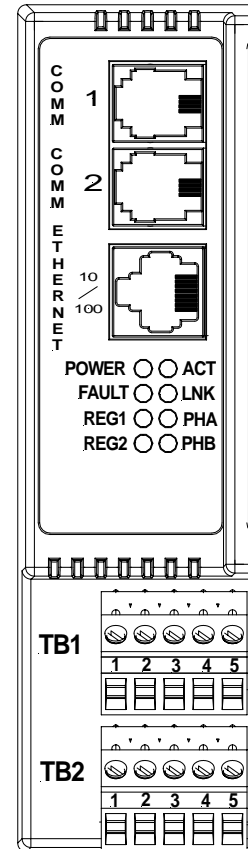

Notes

1. Series RC (75.0 Ω resistor / 0.001μF capacitor) to chassis for optional ground terminations.
2. On-board encoder and registration inputs are only present on the Models 5102 and 5104 controllers.

Minimum hardware revision: B, C, E
Minimum firmware revision: 4.04
Document number: 950-510001-0007

5100 dimensions

Dimensions are in inches (mm). DIN rail clips are standard.

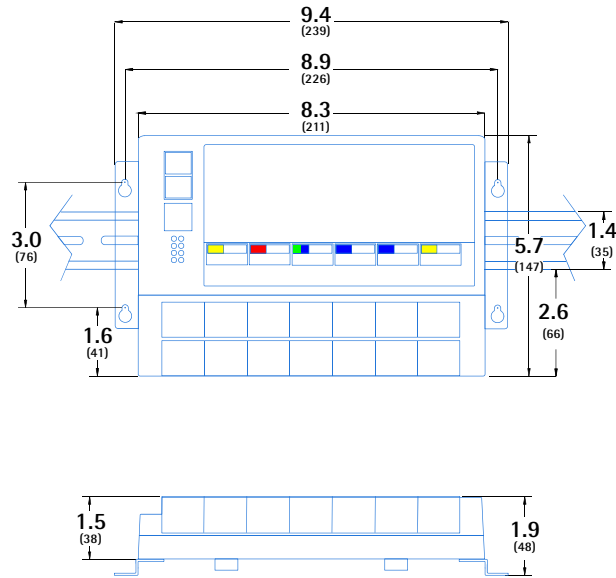

SHOWN WITH OPTIONAL FLUSH MOUNTING BRACKET
Part number: 5180 (includes left and right brackets)

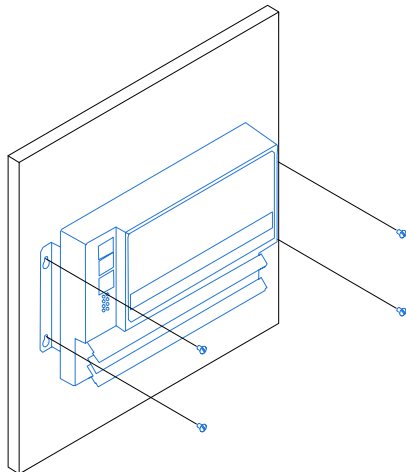

RECOMMENDED MOUNTING ORIENTATION

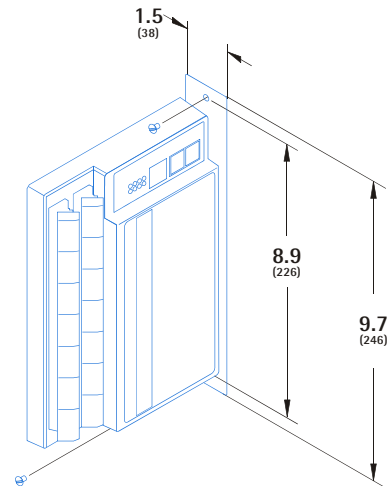

SHOWN WITH OPTIONAL RIGHT-ANGLE MOUNTING BRACKET (Part number: 5181)

5100 configuration

CTC has designed the 5100 series to be easily configurable to meet a wide variety of applications. Ordering is simple: you just select your CPU option and then add the modules needed for your application. Each controller has six internal module bays that can accommodate any combination of I/O or motion control modules. The 5100 model options as well as a sample configuration are shown below.

5100 Series Part Numbers

The part number for the controller at right is as follows:

Part No. 5102-ABBCSS

Controller _____ Installed modules series

- Controller model _____
- 01 = 18-32 VDC
 - 02 = 18-32 VDC with encoder option
 - 03 = 10-32 VDC
 - 04 = 10-32 VDC with encoder option

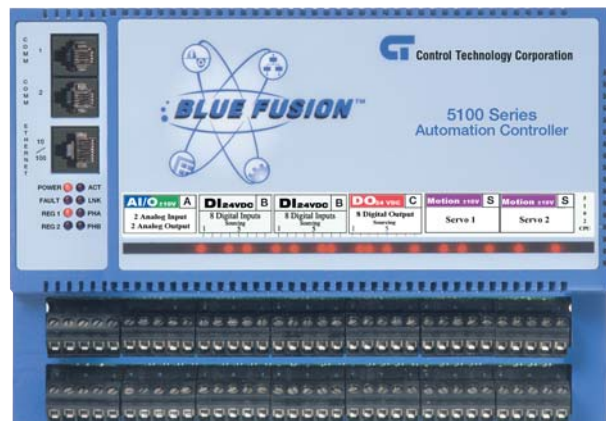

Use the table below to select the controller series that will fit your application.

Model	5101	5102	5103	5104
Input power	18-32 VDC	18-32 VDC	10-32 VDC	10-32 VDC
Module bays	6	6	6	6
Digital inputs	48	50*	48	50*
Digital outputs	48	48	48	48
Analog inputs	24	24	24	24
Analog outputs	48	48	48	48
Servo axes	4	4	4	4
Ethernet ports	1	1	1	1
Master encoders	0	1	0	1
RS-232 channels	2	2	2	2

*Includes two high speed inputs on controller mother board in addition to standard per-controller maximum of 48 inputs.

**Capacities are per controller and are not necessarily mutually inclusive.

Accessory part numbers

Flush mounting brackets: 5180 (includes left and right brackets)

Right-angle mounting bracket: 5181