

Mercury II™ 1900

The Next Generation of High Performance Encoders

High Performance Analog 1Vpp Output with Linear Tape or Glass Scales



Resolution

Determined by Customer Electronics
Linear: 5µm to 1.2nm*

*1.2nm resolution requires x16384 customer interpolation

Accuracy

Tape Scale: ± 5µm/m

Glass Scales:

± 1µm available

± 1.5µm to ± 5µm standard

Outputs

Analog 1Vpp Sin/Cos and Index Pulse

Scales

Same Sensor for Tape or Glass

The new Mercury II 1900 encoder represents a breakthrough in performance, offering high signal quality for high resolution and accuracy, small sensor size, unmatched versatility, robustness, and easy installation. Use cut-to-length tape scale or use glass scales for the highest accuracy. Connector options are 15 pin standard D-sub or customer specified.

Mercury II: The Next Generation

A Breakthrough in High Performance Encoder Technology

MicroE Systems revolutionized encoder technology with the original Mercury encoder family. Smaller, faster, and smarter than anything before, it set the standard for innovation. Now Mercury II, MicroE System's newest family of reflective incremental encoders, takes another giant step forward by giving you "best-in-class" performance, unparalleled versatility, exceptional robustness, and unmatched ease of use. You get all of this from a single encoder system.

MII1900 offers high signal quality for customer interpolation, enabling excellent performance in high speed, high resolution applications.

System Features at a Glance

- Analog 1Vpp sin/cos output and index window
- Small sensor - 8.7mm tall sensor fits tight spaces
- Faster - 7.2m/s
- Versatile - same sensor for linear tape or glass scales
- Cut-to-length laser tape scale comes in a dispenser in lengths up to 30m
- Low power consumption

- Stick-on, bi-directional optical index
- High tolerance to scale contamination
- Broadest alignment tolerances and easy setup using alignment tool LEDs
- Differential outputs for high reliability in high EMI environments
- Available software can be used for encoder setup, monitoring and diagnostics
- CE and RoHS compliant

Optional Features

- Tape scale length - up to 30m per dispenser
- Glass scale lengths from 10mm to 1m
- Sensor cable length of 1m, 3m, 5m, or custom
- Standard 15 pin D-sub connector or micro-connector
- Accessory Kits for scale installations
- SmartPrecision™ II Software



Table of Contents

OverviewPg. 1-2
 FeaturesPg. 3-4
 Specifications and OutputsPg. 5-6

SmartPrecision II SoftwarePg. 7
 ScalesPg. 8-12
 Ordering InformationPg. 13-14

System Configurations

Standard and Optional Equipment

Mercury II™ 1900S Encoder System Standard Equipment



Encoder Sensor



Controller Interface Cable



MII 1900S
RS-422 compliant
15 pin standard
D-sub connector



SmartPrecision™ Alignment Tool for Setup- ATMII1900

Provides fast set up; the built-in LED indicators make alignment fast and easy, eliminating the need for an oscilloscope.

The RS232 Interface Adapter provides power to the encoder and connections to a PC. This is included with the Alignment Tool.

Optional Software

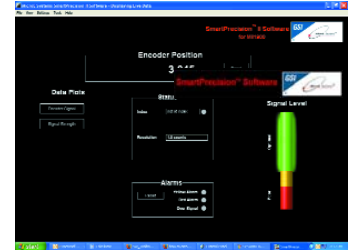

SmartPrecision II Software

Optional software lets you view signal strength, Lissajous plots, position data and diagnostics.

Installation Accessories



Stick-on Index Marker



Tape Scale Applicator Tool



Tape Scale Shears

MII 1900 System Features at a Glance

The Mercury II™ 1900 is built on the field-proven Mercury™ technology platform. Known for being smaller, smarter and faster, Mercury II builds on the original Mercury series and adds increased performance, versatility, robustness, and ease-of-use.

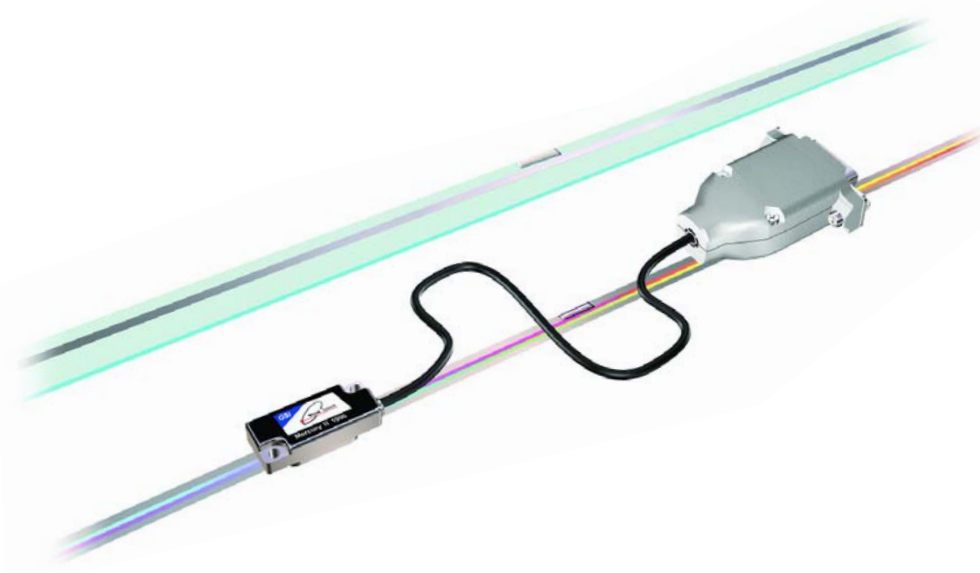

Mercury II 1900's features include:

- Small, low-mass sensor with ultra low Z-height fits in compact motion systems
- Low noise, high accuracy output signals - resolution up to 1.2nm; long-range accuracy up to $\pm 1\mu\text{m}$ (linear glass scales up to 130mm long)
- High-speed operation - 7.2m/s
- Versatility - one sensor works with laser tape or linear glass scales
- Broad sensor alignment tolerances and the Alignment Tool's red/yellow/green setup LEDs make sensor alignment fast
- Low power consumption - only 48mA with A, B and I outputs terminated
- Robustness features include all differential outputs and double-shielded cabling for superior EMI/RFI immunity; scale contamination resistance insures encoder operation even with fingerprints, oil, dust and other forms of contamination
- Optional software makes setup, motoring and diagnostics easy



- Adhesive-mount laser tape scale supplied in continuous lengths for cut-to-length convenience and inventory savings; mounts on virtually any surface - metals, granite, glass, composites, or ceramics

- The stick-on optical index can be placed anywhere, is easy to apply, requires no adjustment, and works on both laser tape and linear glass scales
- Convenient tape scale applicator tool insures consistency and speeds installation

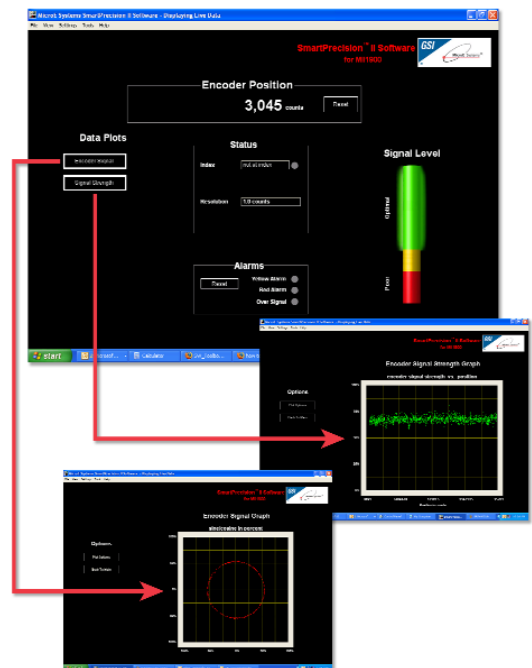

Smallest Sensor, Lowest System Height, Smallest Tape Scale System, Broader Alignment Tolerances, and More

Why Mercury II™ Encoders Make It Easier To Design High Performance Into Your Equipment

Mercury II Can Reduce System Size and Cost

Mercury II's system height with tape scale is 36% shorter than competitive encoders, making it easier to fit into your design. This reduction can also cut motion system weight and cost by allowing the use of smaller motors and stages. This significantly relaxes mechanical system tolerances, while reducing system costs. Mercury II's optical index marker is placed within the 6mm width of the tape scale, saving even more space by eliminating external index and tape scale carrier bulk.

Smallest Tape Scale System

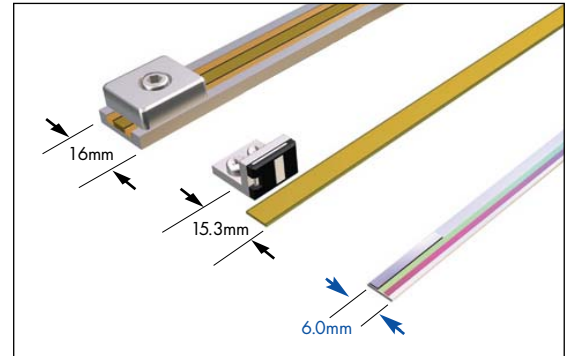

Lowest System Height

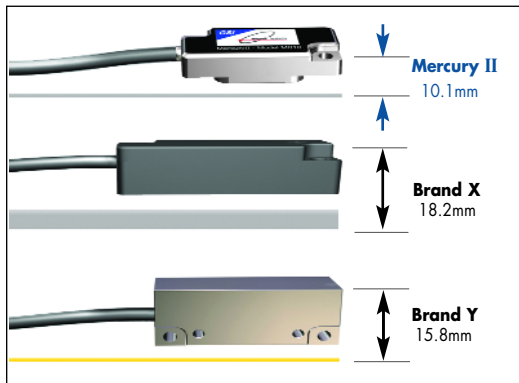

Mechanical Dimension Comparison*

	Mercury II with Tape Scale	Brand X	Brand Y	Mercury II vs. Best Competitor
System height	10.1mm	18.2mm	15.8mm	56% better
Sensor Z height	8.7mm	12mm	14.8mm	38% better
Standoff tolerance	± 0.15mm	± 0.1mm	± 0.1mm	50% better
Tape scale width**	6.0mm	16.0mm	15.3mm	155% better

*Based on published specifications

**Tape scale system width including index

Theta Z Alignment Tolerance Eliminate the Frustration of Touchy Encoder Alignment

Mercury II Solves this Problem for Good

Fussy alignment is no longer a concern. With Mercury's patented PurePrecision™ optics, advanced SmartPrecision II™ electronics and LED alignment indicators, you can push the sensor against your reference surface, tighten the screws and you're finished. Try that with Brand X or Y.

This performance is possible thanks to relaxed alignment tolerances, particularly in the theta Z axis. Mercury II offers a ± 2° sweet spot – that's a 300% improvement over the best competitive encoder. And that will result in dramatic savings in manufacturing costs. No other commercially available encoder is easier to align, easier to use, or easier to integrate into your designs.

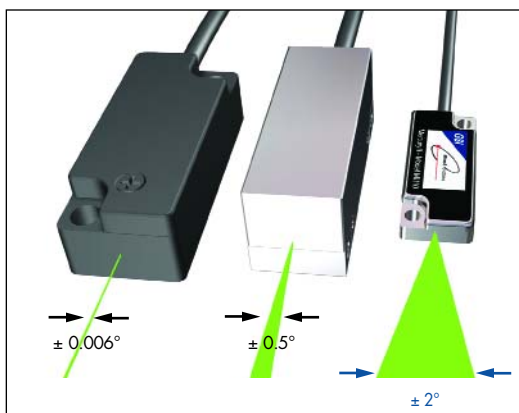

Alignment Tolerance Comparison*

	Mercury II***	Brand X	Brand Y	Mercury II vs. Best Competitor
theta Z	± 2.0°	± 0.006°	± 0.5	Mercury is 300% better
theta Y	± 1.0°	unspecified	± 1.0°	
theta X	± 1.0°	± 0.1°	± 1.0°	

*Based on published specifications

***Measured at a constant temperature for one axis at a time with all other axes at their ideal positions.

System Specifications

System

Scales:

- Cut-to-length PurePrecision™ laser tape scale - available in continuous lengths up to 30m
- Linear glass scales for high accuracy

Grating Period	20µm
Signal Period	20µm
System Resolution	5µm - 1.2nm; determined by customer electronics
Linear accuracy*	

	Laser Tape Scale	Glass Scales
Short-travel Accuracy	Determined by correction of gain mismatch, offset and phase in the customer electronics	
Long-travel Accuracy	± 5µm/m after two-point linearization in the customer's controller	<p>High accuracy grade: ≤ ±1µm for scales up to 130mm ≤ ±2µm for scales from 130mm to 1m</p> <p>Standard accuracy grade: ≤ ±1.5µm for scales up to 130mm ≤ ±5µm for scales from 130mm to 1m</p>

*Maximum error over the specified movement when compared to a NIST-traceable laser interferometer standard, used at room temperature.

Index: stick-on optical marker can be placed anywhere; bi-directional, full speed.

Sensor Size

W:	13.49mm	0.531"
L:	32.00mm	1.260"
H:	8.73mm	0.344"

Operating and Electrical Specifications

Power Supply: 5VDC ±5% @ 48mA when used with recommended termination (see installation manual)

Temperature
 Operating: 0 to 70°C
 Storage: -20 to 85°C

Humidity: 10 to 90% RH non-condensing

EMI: CE Compliant

Shock: 300G 0.5 ms half sine

Vibration: 30G at 17Hz

Sensor Weight: 6g (Sensor without cable)

Sensor Cable: Double Shield
 Maximum length: 20m (contact MicroE Systems for applications >5m)
 Diameter: 3.6mm (0.142")
 Flex Life: 20 x 10⁶ cycles @ 20mm bending radius

Reliability Information

5 year Expected Reliability: >99.8% under normal operating conditions.

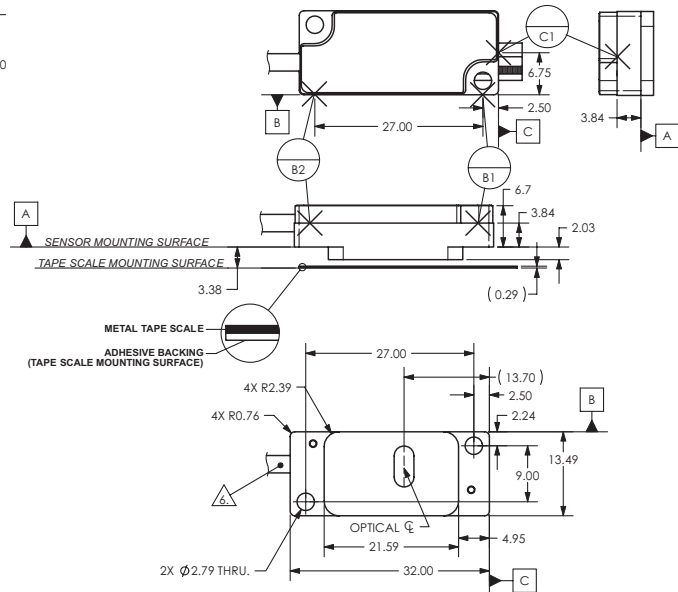
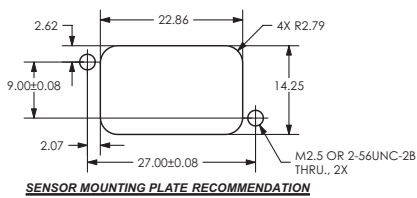
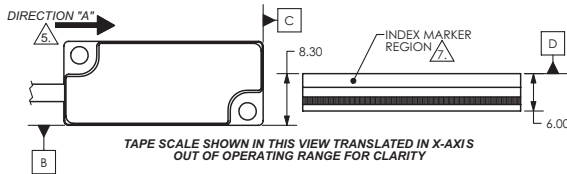

NOTE:

Sensor shown with tape scale. Refer to the Mercury II™ interface drawings for additional dimensional details and important notes.

System Specifications

Analog Outputs

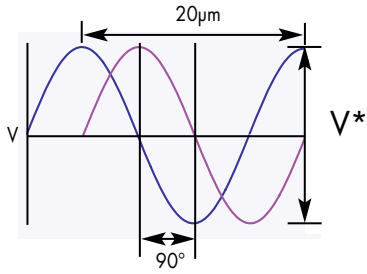

*Tape scales: 0.6 - 1.2Vpp (Differential)
Across 120 Ohm termination

*Glass scales: 1.0 - 1.4Vpp (differential)
across 120 Ohm termination

*Other signal amplitudes available in
OEM quantities

Index Window

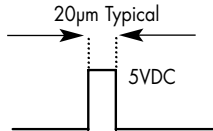

MII 1900S

PIN	FUNCTION
1	SIN -
2	COS -
3	Index Window +
4	5V
5	5V
6	Not Used
7	Not Used
8	Not Used
9	SIN +
10	COS +
11	Index Window -
12	GND
13	GND
14	Not Used
15	Do Not Connect

GND and Inner Shield are internally connected

MII 1900S

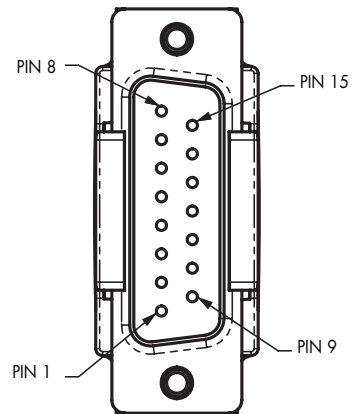
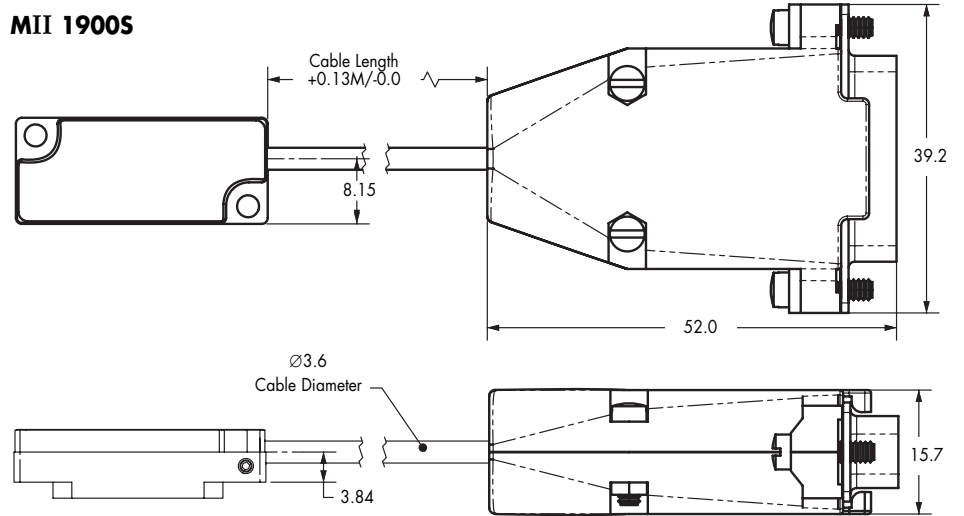

SmartPrecision II™ Software

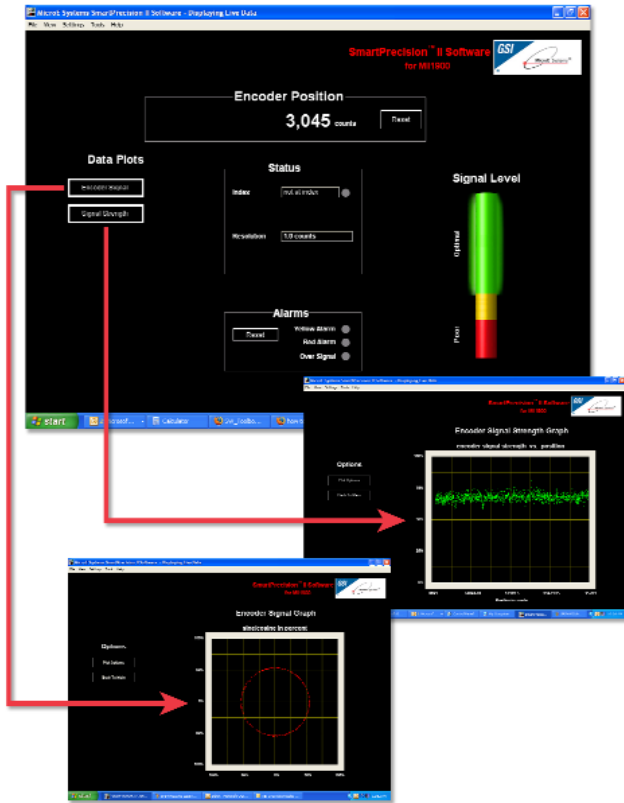

Why use software with an encoder?

The answer: To get more performance from your motion system.

Mercury II™ 1900's simple LED alignment process does not require use of the software. However SmartPrecision II Software adds unique functionality:

- Perform setup using the Signal Level display, Lissajous plots, and Signal Strength plots
- Monitor system operation using digital readouts and software alarms
- Perform diagnostics using displays and data plots
- Email Lissajous plot screen captures to MicroE Systems for remote diagnostic support, no matter where your equipment is located

SmartPrecision II Software performs setup, monitoring, and diagnostics. Its features include displays of:

- Encoder output counts
- Encoder signal level
- Status of index
- Software alarms
- Lissajous plot
- Signal strength vs. Position plot

Setup Mercury II Encoders

- Align sensors using the Signal Level display and Lissajous plots
- Verify index mark performance and see when the sensor has passed over the scale's index mark
- Verify sensor output over full scale travel using the Signal Strength vs. Position plot

Monitor Mercury II Encoder Operation

- Read encoder position in units of scale line counts
- Monitor signal level alarms

Diagnose Mercury II Encoder Performance

- Use Lissajous and Signal Strength plots as diagnostic tools
- Email screen captures to MicroE Systems for rapid technical support
- Monitor alarms

Computer Requirements

- Windows 2000, XP or Vista
- RS-232 serial COM port (for computers without a COM port, such as many laptops, use Keyspan USB adapter, part number USA-19HS)
- SmartPrecision Alignment Tool, model ATMII1900S or ATMII1900H

PurePrecision™ Laser Tape Scale with Stick-On Index

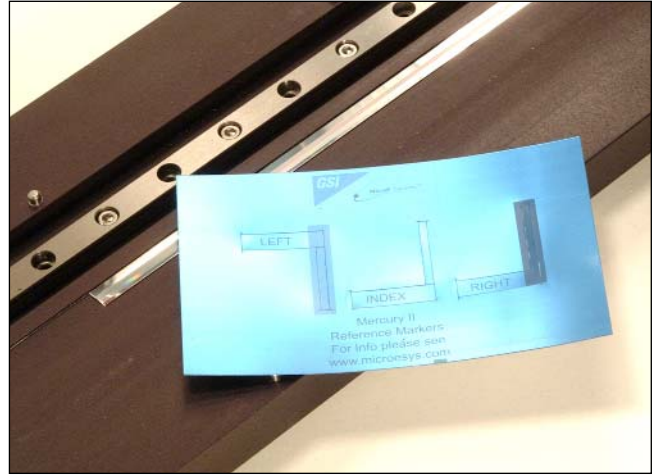

Mercury II™'s PurePrecision laser tape scale is fast and easy to install, provides excellent accuracy and takes less space than any encoder in its class. It mounts using a permanent pressure-sensitive adhesive. Thermal expansion of the substrate is matched by anchoring the ends of the tape scale using epoxy and end caps.



Tape is supplied in a dispenser in lengths up to 30m so that you can cut any length required for your application, minimizing inventory costs, or it may be ordered pre-cut to any length you specify for high-volume OEM applications.

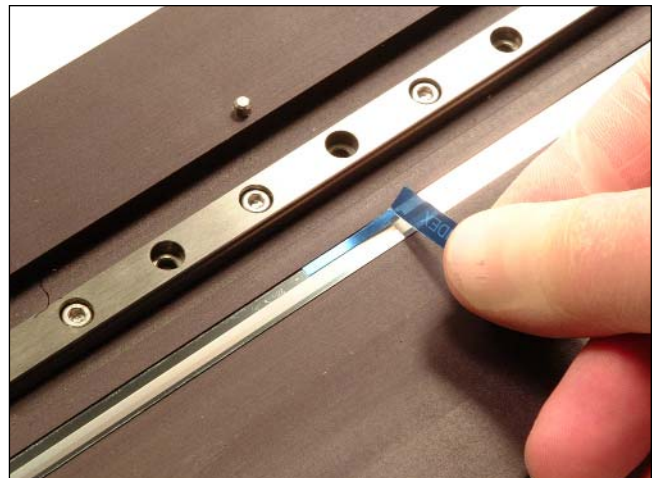

Installation for a wide range of lengths is fast and easy using MicroE Systems' tape applicator tool, or without a tool by hand. When using the installation tool, release paper is automatically removed from the tape. The tape's location on the mounting surface is set by a reference edge that is either machined into the substrate or is put in place temporarily.



The stick-on (adhesive-mount) optical index marker is mounted on the tape in seconds usually using the same reference edge as for the tape scale. This space-saving design keeps the index marker within the 6mm width of the tape, ideal for space-constrained motion systems. The index is bi-directional and operates at all encoder speeds. View the Tape Scale Installation video at www.microsys.com/MercuryII for a demonstration.



Mercury II PurePrecision tape scale may also be installed using scale applicator tools for 6mm-wide tape from other manufacturers.

PurePrecision™ Laser Tape Scale with Stick-On Index

The laser scale length that you specify for your application must be calculated as follows. This calculation applies whether you are using end caps or not. 20mm at each end of the tape scale are not to be used for encoder feedback.

Tape Scale Length = Measuring Length + 40mm

Example: Measuring Length of 800mm is required, and end caps will be used at the end of the tape scale. The Tape Scale Length = 800mm + 40mm = 840mm.

Specifications

Accuracy	±5µm/m after two-point linearization in the customer's controller
Material	Inconel 625
Typical CTE	13ppm/°C; thermal behavior of the tape scale is typically matched to the substrate using epoxy at the ends of the tape scale

Index Marker and End Cap Locations

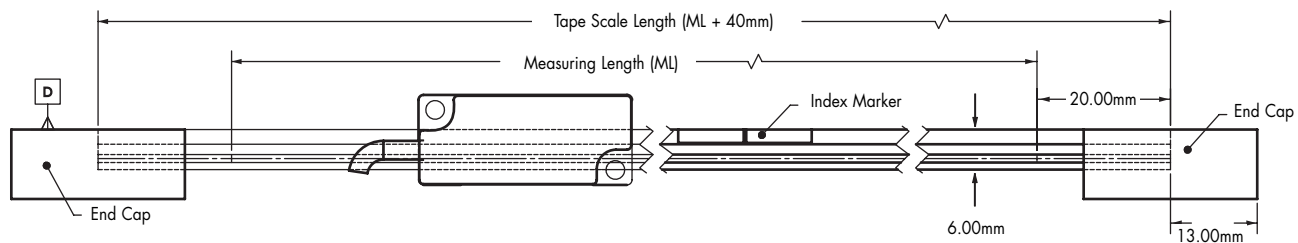

D = Mounting Surface Reference Edge

Available Lengths:

Order as much tape scale as you will require for your production and cut it to length for each job, or order pre-cut lengths to match your application requirements. Note that the Measuring Length for each axis in your equipment will be 40mm less than the Tape Scale Length when end caps are not used. PurePrecision laser tape scale is shipped in tubes for lengths from 40mm - 500mm and in dispensers for lengths greater than 500mm.

Order the required Tape Scale Length using model number TS-xxxxx (where xxxxx = Tape Scale Length in mm [40mm - 30000mm]). Example (9000mm Tape Scale): TS-09000. Contact MicroE Systems for lengths greater than 30m.

Linear Glass Scales with Stick-on Index

MicroE Systems offers chrome on glass scales in a wide range of lengths and two accuracy grades. Easy to install, choose from standard linear scales or customized scales where needed. Use linear glass scales when you need higher accuracy or thermal performance than tape scales.

Glass Scale Options

- Standard linear: 10mm - 1m (consult MicroE for longer lengths)
- Custom linear*: special lengths, widths, thickness, index mark locations, pre-printed index, and special low CTE materials

*Custom scales are available in OEM quantities. Contact your local MicroE Systems sales office.

Linear Glass Scale Features

Mercury II linear glass scales 130mm or shorter are only 6mm wide, enabling drop-in replacement of existing 6mm wide tape scale encoders for dramatic improvements in motion system resolution and accuracy.

The stick-on (adhesive-mount) optical index marker is mounted on the scale in seconds usually using the same reference edge as for the scale or a metal block. This space-saving design keeps the index marker within the 6mm width of the scale, ideal for space-constrained motion systems. The index is bi-directional and operates at all encoder speeds.

The scale length that you specify for your application must be calculated as follows.

$$\text{Glass Scale Length} = \text{Measuring Length} + 5\text{mm}$$

Example: A Measuring Length of 25mm is required. Scale Length = 25mm + 5mm = 30mm.

Factory cut-to-length flexibility:

Mercury II's stick-on index marker makes factory cut-to-length glass scales possible, enabling rapid turnaround for any scale length and helping you exactly match your application requirements. For OEM applications, linear glass scales can be ordered with a pre-printed index, speeding installation.

Standard Short Linear Scales

130mm and Shorter

Dimensions in mm.

Specifications

Accuracy	±1.5µm standard accuracy grade ±1µm available (high accuracy grade)
Material	Soda lime glass
Typical CTE	8ppm/°C

Order the required Scale Length using model number MII Lxxxx where xxxx = Scale length in mm (10mm - 1000mm). Example: (30mm Linear Glass Scale): MII L30.

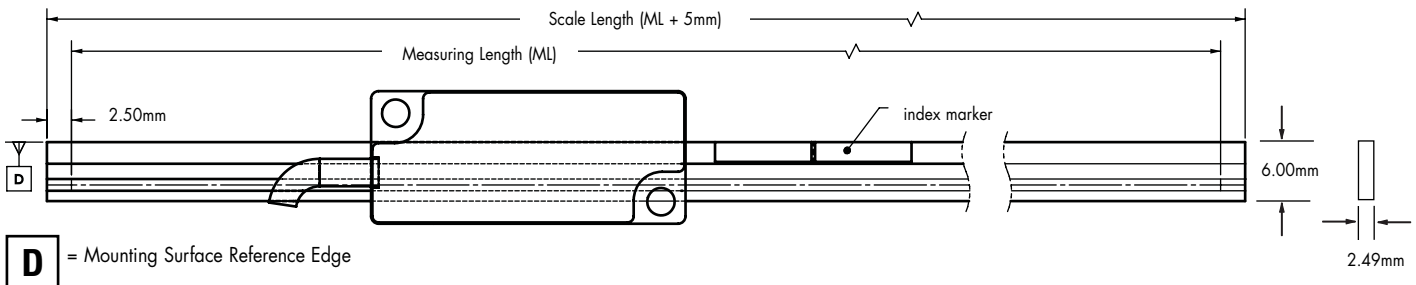

Note: The following are only examples; you can order any size.

Model	MII L18	MII L30	MII L55	MII L80	MII L105	MII L130
Scale Length	18mm	30mm	55mm	80mm	105mm	130mm
Measuring Length	13mm	25mm	50mm	75mm	100mm	125mm

Custom scales available, including scales with pre-printed index

Linear Glass Scales with Stick-on Index

Standard Long Linear Scales

131mm and longer

Dimensions in mm.

Specifications

Accuracy	±5µm standard accuracy grade
	±2µm available (high accuracy grade)
Material	Soda lime glass
Typical CTE	8ppm/°C

Order the required Scale Length using model number MIILxxxx where xxxx = Scale length in mm (10mm - 1000mm). Example: (225mm Linear Glass Scale): MIIL225. Contact MicroE Systems for lengths greater than 1m.

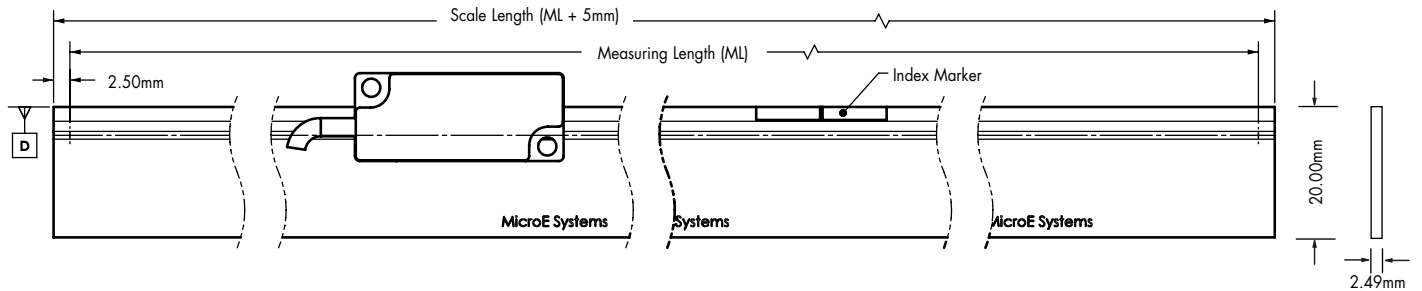

D = Mounting Surface Reference Edge

Note: The following are only examples; you can order any size.

Model	MIIL155	MIIL225	MIIL325	MIIL425	MIIL525	MIIL1000
Scale Length	155mm	225mm	325mm	425mm	525mm	1000mm
Measuring Length	150mm	220mm	320mm	420mm	520mm	995mm

Custom scales available, including scales with pre-printed index

Installation Accessory Kits



Compatible with all Mercury II™ encoder models, Installation Accessory Kits provide everything you need to install Mercury II encoders. Kits come in “non-consumable” and “consumable” styles. Non-consumable kits are designed for first-time buyers. They include the special tools that you only need to buy once, and add all of the consumables needed for five installations. Consumable kits are for customers to reorder after they have used up the consumable materials in the Non-consumable kits. The Consumables Kits include all materials necessary for 10 installations. All Accessory Kits include both Metric and US Customary sensor mounting screws and hex wrenches, and come packaged in a kit for convenient storage. For instructions about how to use the kits, see the installation manual for Mercury II encoders at www.microesys.com/MercuryII.

- MIIAK-1** Non-consumables for Tape Scale Installations
(includes consumables for five installations)
- MIIAK-2** Consumables for Tape Scale Installations
(includes consumables for 10 installations)
- MIIAK-3** Non-consumables for Linear Glass Scale Installations
(includes consumables for five installations)
- MIIAK-4** Consumables for Linear Glass Scale Installations
(includes consumables for 10 installations)

	MIIAK-1	MIIAK-2	MIIAK-3	MIIAK-4
Tape Scale Applicator Tool - for applying tape scale	1			
Tape Scale Shears - for cutting tape scale	1			
Tweezers - plastic with sharp tips	1		1	
Sensor Height Gage - for verifying sensor height	1		1	
Index Marker - for tape or linear glass scales	5	10	5	10
Tape Scale End Caps (two required per tape scale installation)	10	20		
Two-part Epoxy - for mounting scales	5 Packages	10 Packages	5 Packages	10 Packages
Silicone Adhesive - for mounting linear glass scales			1 Tube	1 Tube
Powder-Free Finger Cots	8	15	8	15
Scale Cleaning Tissues	8	15	8	15
Sensor Mounting Screws - M2.5x6mm	10	20	10	20
Sensor Mounting Screws - 2-56UNCx1/4 inch	10	20	10	20
Hex Wrench for M2.5 Screws	1		1	
Hex Wrench for 2-56UNC Screws	1		1	

How to Order Mercury II™ 1900 Encoders, Alignment Tools, and Software

To specify your Mercury II 1900 encoder with the desired cable length, order the required quantities for each system model number below. Order scales and additional items using their model number. Call MicroE Systems' Rapid Customer Response team for more information at 781-266-5700.

Example (MII1900 encoder with 5m cable): MII1950S

MII19XXS

MII1910S = 1m cable

MII1930S = 3m cable

MII1950S = 5m cable

How to Order SmartPrecision Alignment Tool

Required for MII1900 setup

Example (Alignment Tool for Mercury II 1900 encoder, 120 VAC): ATMII1900S-120

<u>ATMII1900S</u>	—	<u>Voltage</u>
		120 = 120 VAC, 60Hz US Std. 2-prong plug
		220 = 220 VAC, 50Hz European Std. 2-prong plug

How to Order SmartPrecision II Software

Optional for ATMII1900 Alignment Tool

SPSWMII-AT

SmartPrecision II software on CD and interface cable

How to Order PurePrecision™ Laser Tape Scales

Example (8000mm Tape Scale): TS-08000

TS-xxxxx Where xxxxx = Tape Scale Length in mm
(40mm - 30000mm).

MS

MS = One index marker

EC

EC = One bag of tape scale end caps (10 per bag)

Note: two end caps are recommended per tape scale installation

PurePrecision Linear Glass Scales

(Standard accuracy grade)

Example (350mm Linear Glass Scale): MIIIL350

MIIILxxxx Where xxxx = Glass Scale Length in mm
(10mm - 1000mm).

(High accuracy grade scales: consult MicroE Systems)

Note: index markers must be ordered separately - one per linear glass scale

How to Order Mercury II™ Encoder Systems

Installation Accessory Kits

Example (Consumables Kit for Tape Scale Installations): MIIAK-2

MIIAK – Kit Number

- 1 = Kit 1, Non-consumables for tape scale installations. Includes consumables for (5) installations.
- 2 = Kit 2, Consumables for tape scale installations. Includes consumables for (10) installations.
- 3 = Kit 3, Non-consumables for glass scale installations. Includes consumables for (5) installations.
- 4 = Kit 4, Consumables for glass scale installations. Includes consumables for (10) installations.

Mercury II Encoders Are Fully RoHS-Compliant

Mercury II is fully compliant with European Directive 2002/95/EC (Restriction of use of Hazardous Substances, "RoHS"). A Document of Compliance is available upon request. "Mercury™" is a brand name of MicroE Systems; Mercury and Mercury II encoders do not contain any mercury metal.

Vacuum-Rated and Small Diameter Rotary Encoders

See www.microesys.com/mercury for Mercury linear and rotary encoders that are vacuum rated up to 10^8 torr, small-diameter rotary encoders with scale outside diameters from 32mm to 12mm and low-cost PCB mount encoders.

All specifications are subject to change.

MicroE Systems - World Headquarters: 125 Middlesex Turnpike, Bedford, MA 01730

DS-MII1900 Rev. H

www.microesys.com

info@microesys.com

T. 781-266-5700

F. 781-266-5112

©2011 MicroE Systems